

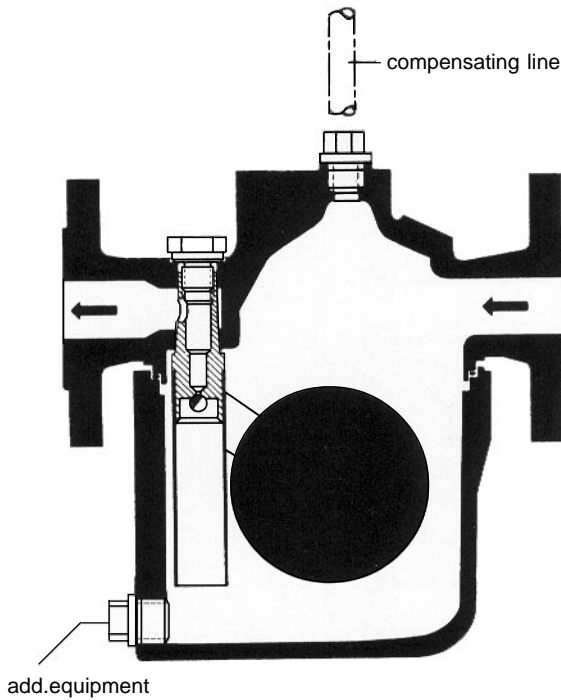

RIFOX

RIFOmat Float - Trap, Type WU 1101-N, PN25

RIFOmat Float Trap , Type WU 1101-N, PN 25



Type WU 1101-N

Performance

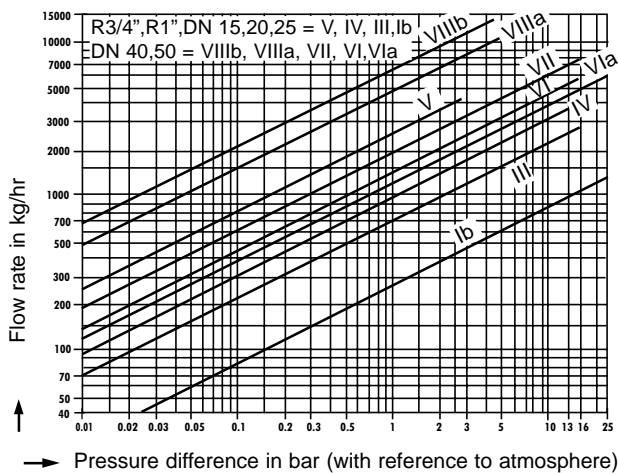

For hot condensate performance value is approx. 32% lower.

Connections :

G3/4 threaded port in flange DN 20, flanges DN 15, 20, 25, 40, 50, PN 25, connection dimensions acc. to DIN 2501, welding ends and other flange standards on request.

Nominal pressure stage : PN 25

Operation limits :

Max. operating pressure, bar g	22	20	17
Max. operating temperature, °C	100	200	300

Media : Agressive media. Cooling agents upon request.

Functional description : Increasing level opens and decreasing level closes the outlet without delay, independent of pressure and temperature fluctuations.

Special characteristics : Only one moveable point since the rotary-slide-valve is both swivel joint and shut-off device.

Installation : Horizontal installation

Additional equipment against extra price :

- Drain plug
- Connection for gas compensating line replacing control screw
- Internal vent valve (steam only)
- Housing seal : SS ridge profiled in place of PTFE for temperatures above 150 °C
- Control unit with special cross-section V, VIIIa, and VIIIb
- Float control assembly for special application
- Control valve replacing control screw
- Easing lever

Type WU can be provided with a light float (e.g. media with a specific gravity of less than 1). Range of applications on request.

Functional limit control :

Cross-section	Line pressure in bar	
	Hot condensate	Cold water
lb	20	25
III	13	16
IV	11	14
V	2.5	2.8
VI	16	16
Vlla	20	25
VII	15	16
VIIIa	4	5
VIIIb	4	4.5

When placing orders, please specify : Medium, density, line pressure, backpressure, temperature, quantity of condensate (kg/h).

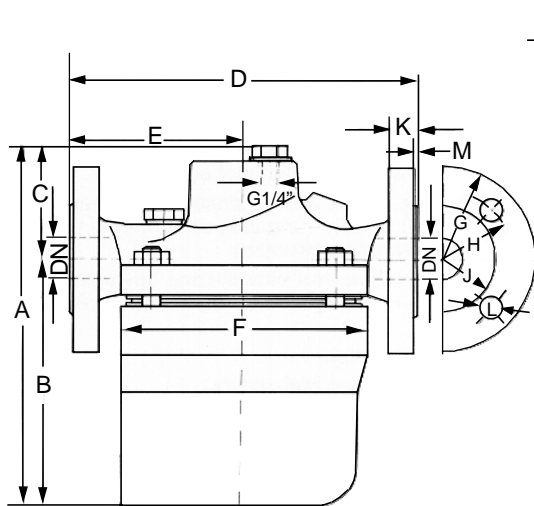

Dimensions (in mm), Weight (in kg)

DN	15	20	25	40	50	G3/4"
D	215	215	215	320	320	215
B	150	150	150	220	220	150
C	65	65	65	80	80	65
A	215	215	215	300	300	215
E	108	108	108	160	160	108
F	152	152	152	230	230	152
G	95	105	115	150	165	
H	65	75	85	110	125	
J	45	58	68	88	102	
K	18	18	18	20	20	
L	14	14	14	18	18	
M	2	2	2	3	3	
Weight	10	10.5	11	26.5	28	9

Spare Parts For Type WU 1101-N with material data

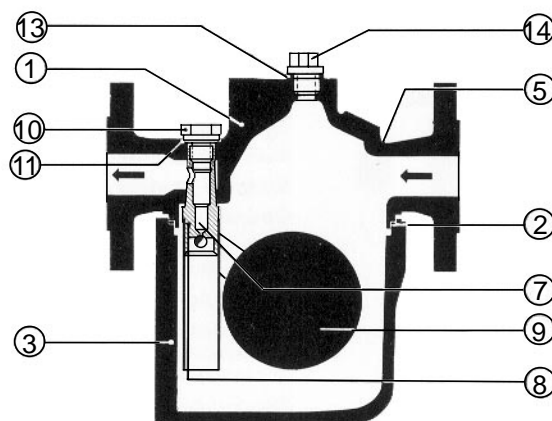

- 1 Upper housing : 1.4581 (1.4552*)
- 2 Housing seal : PTFE or SS ridge profiled
- 3 Lower housing : 1.4581 (1.4552*)
- 5 DN 15 - 25 : Set of stud bolts with nuts :
M 14 DIN 939 / DIN 934, A4 - 70/A4
DN 40/50 : Set of hexagonal bolts with nuts :
M 16 DIN 931 / DIN 934, A4 - 70/A4
- 7 Float control assembly including supporting plug : 1.4571 / 1.4571 hardcor treatment
- 8 Support assembly with rotary valve and cotter pin** : 1.4571 / 1.4571 hardcor treatment
- 9 Float and lever : 1.4571
- 10 Supporting plug : 1.4571
- 11 Seal : PTFE or SS* ridge profiled
- 13 Seal : PTFE or SS* ridge profiled
- 14 Plug : 1.4571

* Depends on operating conditions

** Due to sealing requirements marked items cannot be supplied as individual parts.

To ensure correct parts delivery, specify part number, Works Standard-Sheet number, DN and for control components the cross-section.