



ADCA

Centrifugal Air and Dirt Separators for Liquid systems AS - AS/F

Description

The AS centrifugal air and dirt separators are designed for use in the flow line of a hydronic heater or cooling system. The operation is based on the principle of centrifugal force, instead of relying on low velocity separation, offering the advantage of efficient separation in a smaller vessel.

ADCA AS units provides maximum separation efficiency while minimizing space requirements.

The inside strainer protects against any dirt present in the system such as sand, welding residues, etc. The strainer screen position has a particular advantage compared with external pipe strainers because the dirt is removed from the water flow and is collected in the reservoir bottom avoiding pressure drop increasing.

Connections are female screwed or flanged.

Options : Galvanised and complete stainless steel construction.

Use: To remove air and dirt in hydronic heating, cooling and pumping systems.

Available

Models : AS/S - carbon steel body.
AS/SZ - zinc plated body.
AS/SS - stainless steel body.
AS/SF - carbon steel with strainer

Sizes : Screwed : DN 1-1/4" to DN 2"
Flanged : DN 32 to DN 300

Connections : Female screwed ISO 7/1Rp (BS21)
Flanged EN 1092-1 or ANSI
Special flanges upon request.

Installation : The AS separators should be installed at the highest temperature and lowest pressure points where solubility is lower.

Ideally they should be installed after boilers or heat exchangers, before chillers and before pump suction.

Horizontal installation always with the drain discharge pointing downwards.

An ADCA AE series air eliminator is recommended to remove the air.

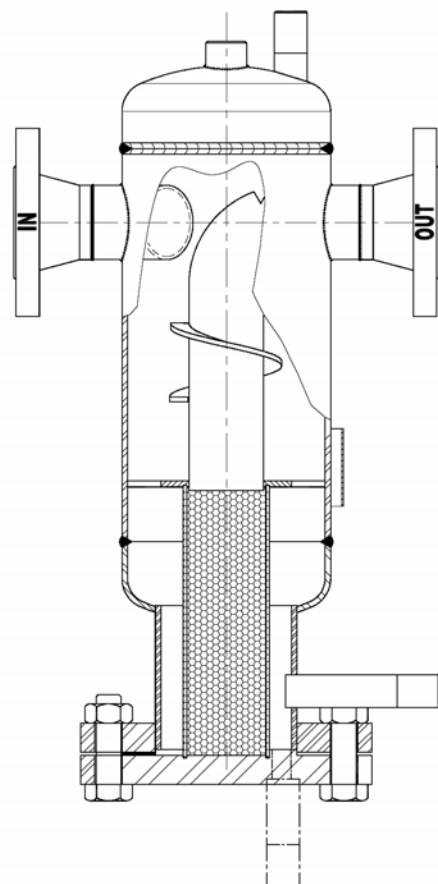
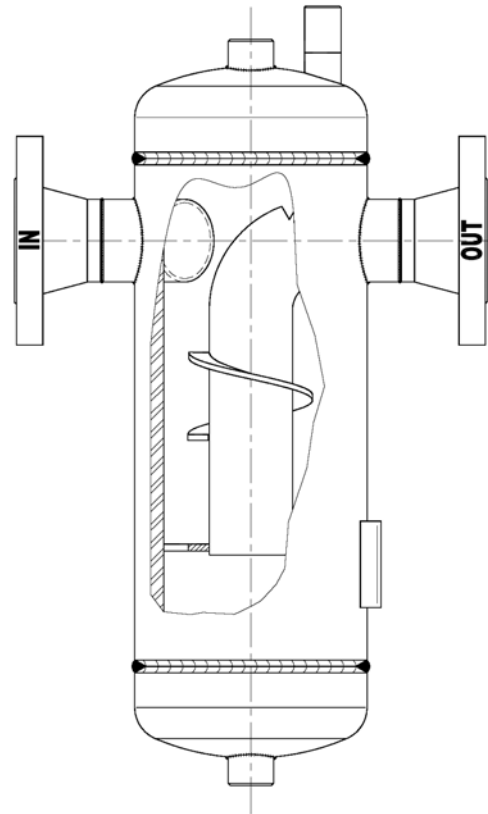



STEAM EQUIPMENT

LIMITING CONDITIONS											
Rating	Press. bar	Temp. °C	Rating	Press. bar	Temp. °C	Rating	Press. bar	Temp. °C	Rating	Press. bar	Temp. °C
PN16	16	120	ANSI Cl.150 lbs	16	120	PN25 ANSI CL.300lbs	25	120	PN40 ANSI CL.300lbs	40	120
	14 *	198		14 *	198		21 *	220		32 *	239
	13	250		-	-		17	300		28	300

*PMO-Max.operating pressure for saturated steam. Minimum operating temp.: -10°C. Design code: AD-Merkblatt

CE MARKING - GROUP 2 LIQUIDS CATEGORIES								
RATING	SIZE	CAT.	RATING	SIZE	CAT.	RATING	SIZE	CAT.
PN16	DN32 to DN300	SEP	PN25	DN32 to DN250	SEP	PN40	DN32 to DN200	SEP
	-	-		DN300	1		DN250 to DN300	1

CE Marking

This product have been designed for use on water and other liquids which are in Group 2 of the PED-European Pressure Equipment Directive 97/23/EC and it comply with those requirements.

The product carries the CE mark when falling in category 1 and above.

MATERIALS		FLANGE CONNECTIONS			
DESIGNATION	MATERIAL	Rating	Sep. SIZE	EN STD.	ANSI STD.
Body	EN10216-2 / P235GH / 1.0325	PN16	* DN32 to DN50	EN1092-1 PN40	ANSI B16.5 Cl.150 lbs
Heads	EN10028-2 / P265GH / 1.0425	PN16	DN65 to DN300	EN1092-1 PN16	ANSI B16.5 Cl.150 lbs
Inlet / Outlet pipes	EN10216-2 / P235GH / 1.0325	PN25	DN15 to DN150	EN1092-1 PN40	ANSI B16.5 Cl.300 lbs
EN Flanges	EN10222-2 / P250GH / 1.0460	PN25	DN200 to DN300	EN1092-1 PN25	ANSI B16.5 Cl.300 lbs
ANSI flanges	ASTM A105 / 1.0432	PN40	DN15 to DN300	EN1092-1 PN40	ANSI B16.5 Cl.300 lbs
Sockets	ASTM A105 / 1.0432	* Flanges EN 1092-1 PN16 and PN40 from DN15 to DN50 has the same number and size of holes.			
Internals	EN10025-2 / S235JR / 1.0038				
Strainer	AISI304 / 1.4301				

EN10204 3.1 certificate available if requested with the order.

APPROXIMATE DIMENSIONS (mm)																		
FLANGED EN1092-1 - ANSI																		
SIZE DN	A1 PN16	A PN16	A PN25	A PN40	A 150lbs	A 300lbs	B	C	C1	D	D1	E	F	F1	G	H	VOL. * dm3	WGT ** Kg
32	263	260	260	260	290	306	140	395	495	285	385	110	3/4"	1/2"	1/2"	3/4"	6	13
40	263	260	260	260	294	307	140	435	535	325	425	110	3/4"	1/2"	1/2"	3/4"	6,7	14,3
50	322	310	310	310	341	354	168	505	605	385	485	120	3/4"	1/2"	1/2"	3/4"	11,7	21
65	-	380	394	394	430	442	219	550	670	410	530	140	1"	3/4"	3/4"	1"	19,8	31,5
80	-	400	416	416	440	459	219	610	730	462	582	148	1"	3/4"	3/4"	1"	27	40
100	-	485	511	511	533	553	273	715	835	528	648	187	1 1/4"	3/4"	3/4"	1 1/4"	38	59,8
125	-	535	561	561	605	622	324	845	995	630	780	215	1 1/4"	1"	1"	1 1/4"	54	84
150	-	585	605	605	635	652	356	962	1112	692	842	270	1 1/2"	1"	1"	1 1/2"	79	161
200	-	605	641	657	685	703	406	1170	1320	880	1030	290	1 1/2"	1"	1"	1 1/2"	146	202
250	-	720	756	790	784	815	508	1540	1710	1140	1310	400	1 1/2"	1"	1"	1 1/2"	288	330
300	-	840	868	914	913	944	610	1700	1870	1172	1342	528	1 1/2"	1"	1"	1 1/2"	412	475

* Volume correspond to the class PN16 AS/F design. Classes PN25 and above may have slightly lower volumes.

** Weight correspond to the class PN16 design.

F, F1, H -screwed drain connection as standard. Alternatively can be supplied flanged EN1092-1 or ANSI on the same class of main dimensions. Consult factory for certified dimensions. Dimensions subject to change without notice.



We reserve the right to change the design and material of this product without notice.

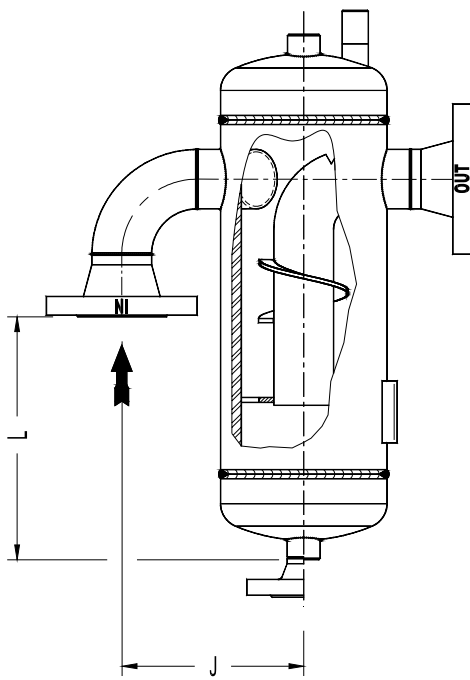
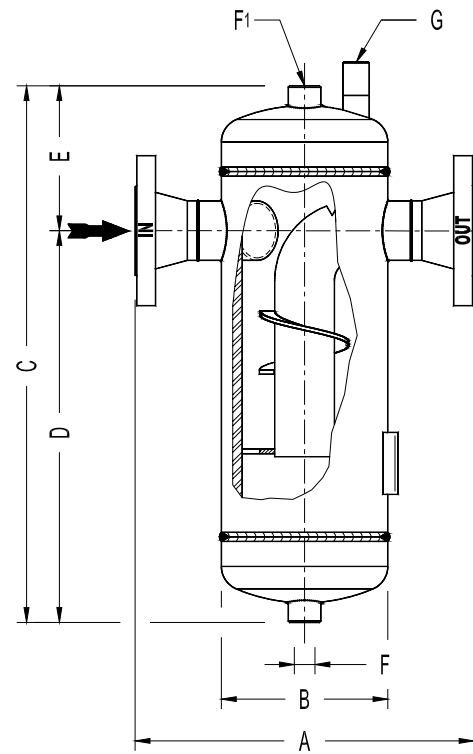
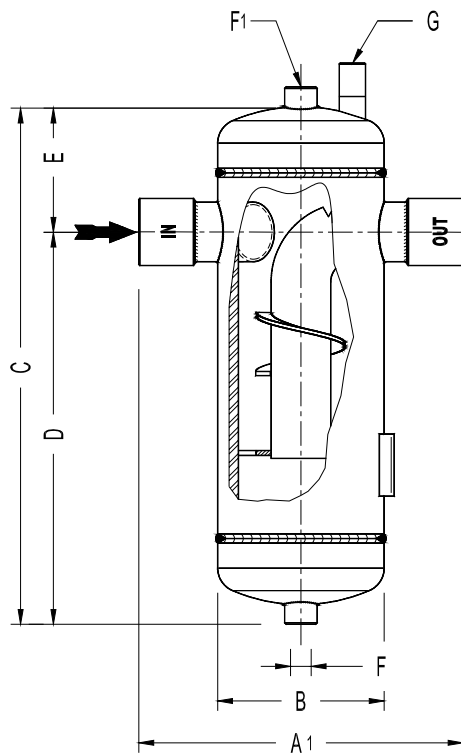

Version EVH

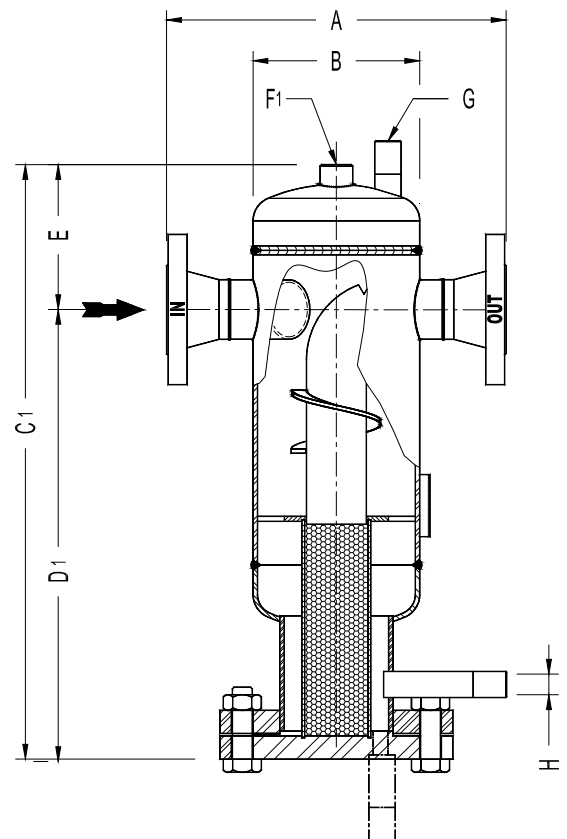

F	Drain connection
F1	Automatic air eliminator connection
G	Manual start up air drain connection
H	Strainer drain connection