

HAWK

All Stainless Steel / SS Case Pressure Gauge

23L, 23B Series



HAWK 23L and 23B series bourdon tube all stainless steel pressure gauges with front flange are designed to fulfill the requirements of high quality from various industries. The wetted parts can be in brass, 316 stainless steel or monel. The 316SS construction pressure gauges are good in use on demanding applications where corrosion resistance, rugged environment resistance and reliable operation are required. Liquid Filling or dampened movement is available to diminish the effects of vibration, pulsation and shock and further enhances the gauge life. These gauges are ideal to use combined with diaphragm seal where recalibration is required.

- Disc Blow Out Protection
- Heavy Duty Bourdon Tube/Rotary Grade Movement
- Excellent Corrosion Resistance Case/Front Flange
- Open Front/ Removable Ring
- Copper Alloy , 316SS or Monel Wetted Parts
- Field Liquid Fillable

Typical Applications:

* Petrochemical and chemical processing * Medical and pharmaceutical industry * Industrial OEM equipments * Food and beverage processing * Hydraulic monitoring systems * Power generating stations * offshore oil platforms * Pulp and paper mills * Pneumatic systems * Level measurement

Specifications

Operating:

Steady: 100%*full scale value

Pulsation: 90%*full scale value

Sudden: 130%*full scale value

The appropriate operating range falls in the middle half of the gauge(25% to 75% of full scale). If you choose the unsuitable range, the fatigue of bourdon tube may be resulted. HAWK Supplies a wide selection of range from vacuum to 15000 PSI including compound range.

Temperature limit:

Ambient: -40 to 100 °C (Dry Gauge)

-10 to 65 °C (Glycerine Filled Gauge)

-50 to 80 °C (Silicon Filled Gauge)

Media: max 60 °C -Brass, 125 °C -SS(Standard)

300 °C (Optional)

Temperature effect:

Accuracy of measurement will be effected by the temperature change. This inaccuracy may as high as $\pm 0.3\%$ for 12 °C temperature change.

Dial Size:

2 1/2"(63mm) or 3 1/2" (85mm)

Case&Ring

Stainless steel 304 case with front flange (SS316-option), polished bayonet ring

Socket

Brass, 316 Stainless Steel or Monel K400

Movement

Brass,Stainless steel movement, silicon dampened movement on request

Bourdon Tube:

Brass, 316-Stainless Steel or Monel K500

30"Hg(Vac) to 900PSI...C-type
1000 to 15000PSI...Helical type

Window:

Plain Glass-standard Tempered Safety, Polycarbonnate or laminated safety glass-optional

Pointer:

Anodized aluminum with black finish

Accuracy:

$\pm 2-1-2\%$ of span
(Grade A to ASME B40.1)

Scale:

PSI, kPa, Mpa, bar, kg/cm², inHg, cmHg, torr, mmHg
(single or dual scale)

Connection:

1/4" or 1/8" NPT standard, JIS, DIN , M14*1.5 available

Mounting :

Flushing panel mounting

Weatherproof:

NEMA 4X/IP65 enclosure

Option:

Tempered safety glass lens

Refrigerant Scale

Receiver Scale 3.... 15 PSI

Stainless steel U-clamp bracket

Steel zinc plated U-clamp bracket

Movement with PTFE coated gear

Silicone Filled

Cleaned for oxygen service

Improved Accuracy 1.0%(Grade 1A-ASME B40.1)

Certification of calibration

Laminated safety glass lens

Ammoniated Scale

Retard Scale

Back flange case

Movement with Titanium coated gear

Glycerine Filled

Threaded snubber in socket

Maximum pointer

Lower Back Connection

Polycarbonate lens

Customer dial

Altitude Scale

Front flange case

Dampened movement

Halocarbon Filled

DIN standard

Electrical alarm contact

Pressure Range:

Pressure Range			D24	0/4kg/cm ² /psi	0.2	D47	0/400kg/cm ² /psi	20
Code	Dial Range	Minor	D25	0/5kg/cm ² /psi	0.1	D48	0/500kg/cm ² /psi	20
D1	0/15 PSI	0.25	D26	0/6kg/cm ² /psi	0.2	D49	0/600kg/cm ² /psi	20
D2	0/30 PSI	0.5	D27	0/7kg/cm ² /psi	0.2	D50	0/700kg/cm ² /psi	20
D3	0/60 PSI	1	D28	0/10kg/cm ² /psi	0.2	D51	0/1000kg/cm ² /psi	50
D4	0/100 PSI	1	D29	0/11kg/cm ² /psi	0.2	D52	0/100kPa/psi	5
D5	0/160 PSI	2	D291	0/14kg/cm ² /psi	0.5	D53	0/200kPa/psi	10
D6	0/200 PSI	2	D30	0/15kg/cm ² /psi	0.2	D54	0/400kPa/psi	20
D7	0/300 PSI	5	D31	0/16kg/cm ² /psi	0.2	D55	0/700kPa/psi	50
D8	0/400 PSI	5	D32	0/20kg/cm ² /psi	1	D56	0/1100kPa/psi	50
D9	0/600 PSI	10	D33	0/25kg/cm ² /psi	1	D57	0/1400kPa/psi	100
D10	0/1000 PSI	20	D34	0/28kg/cm ² /psi	1	D58	0/2000kPa/psi	100
D11	0/1500 PSI	20	D35	0/30kg/cm ² /psi	1	D581	0/2800kPa/psi	100
D12	0/2000 PSI	20	D36	0/35kg/cm ² /psi	1	D59	0/4000kPa/psi	200
D13	0/3000 PSI	50	D37	0/40kg/cm ² /psi	2	D60	0/7000kPa/psi	500
D14	0/5000 PSI	100	D38	0/50kg/cm ² /psi	1	D61	0/14000kPa/psi	1000
D15	0/6000 PSI	100	D39	0/60kg/cm ² /psi	2	D62	0/21000kPa/psi	1000
D16	0/7000 PSI	100	D40	0/70kg/cm ² /psi	2	D621	0/28000kPa/psi	1000
D17	0/10000 PSI	200	D41	0/100kg/cm ² /psi	5	D63	0/35000kPa/psi	1000
D18	0/15000 PSI	200	D42	0/140kg/cm ² /psi	5	D631	0/40000kPa/psi	2000
D19	0/1kg/cm ² /psi	0.05	D421	0/150kg/cm ² /psi	2	D632	0/55000kPa/psi	2000
D20	0/2kg/cm ² /psi	0.1	D43	0/200kg/cm ² /psi	10	D64	0/70000kPa/psi	5000
D21	0/2.5kg/cm ² /psi	0.1	D44	0/250kg/cm ² /psi	10	D65	0/100000kPa/psi	5000
D22	0/3kg/cm ² /psi	0.1	D45	0/300kg/cm ² /psi	10	D66	0/1bar/psi	0.02
D23	0/3.5kg/cm ² /psi	0.2	D46	0/350kg/cm ² /psi	10	D67	0/2bar/psi	0.05

Code	Dial Range	Minor	Dv3	-100kPa/inHg/0	-5	DKK	-76cmHg/10kg/cm ²	1
D68	0/4bar/psi	0.1	Dv4	-1bar/inHg/0	-0.02	DCL	-76cmHg/20kg/cm ²	1
D69	0/7bar/psi	0.1	Compound Range			DCM	-76cmHg/35kg/cm ²	1
D70	0/11bar/psi	0.2	Code	Dial Range	Minor	DCM1	-100/+100 kPa/psi	5
D71	0/14bar/psi	0.2	Dc1	-30inHg/0/15psi	0.5	DCN	-100/+200 kPa/psi	10
D72	0/20bar/psi	0.5	DCA	-30inHg/0/30psi	0.5	DCO	-100/+400 kPa/psi	20
D73	0/28bar/psi	0.5	DCB	-30inHg/0/60psi	1	DCP	-100/+700 kPa/psi	50
D74	0/40bar/psi	1	DCC	-30inHg/0/100psi	2	DCQ	-100/+1000 kPa/psi	50
D75	0/70bar/psi	1	DCD	-30inHg/0/150psi	2	DCQ1	-100/+1400 kPa/psi	100
D76	0/140bar/psi	2	DCE	-30inHg/0/200psi	5	DCR	-100/+2100 kPa/psi	100
D77	0/200bar/psi	5	DCF	-30inHg/0/300psi	5	DCS	-1/+1 bar/psi	0.05
D78	0/350bar/psi	5	DCF1	-76cmHg/1kg/cm ²	0.05	DCT	-1/+2 bar/psi	0.05
D79	0/700bar/psi	10	DCG	-76cmHg/2kg/cm ²	0.1	DCU	-1/+4 bar/psi	0.1
D80	0/1000bar/psi	20	DCH	-76cmHg/2.5kg/cm ²	0.1	DCV	-1/+7 bar/psi	0.2
Vacuum Range			DCI	-76cmHg/3.0kg/cm ²	0.1	DCW	-1/+10 bar/psi	0.2
Code	Dial Range	Minor	DCJ	-76cmHg/4.0kg/cm ²	0.2	DCX	-1/+14 bar/psi	0.2
Dv1	-30inHg/0	-0.5	DCJ1	-76cmHg/5kg/cm ²	0.1			
Dv2	-76cmHg/inHg/0	-2.5	DCJ2	-76cmHg/7kg/cm ²	0.2			

1. The other scales and ranges(DIN) are available in request.
2. Not all listed ranges and scales are in stock, Consult your distributors for available.

Accessories:

Please refer to HAWK diaphragm seal and accessories data sheets for detailed information.

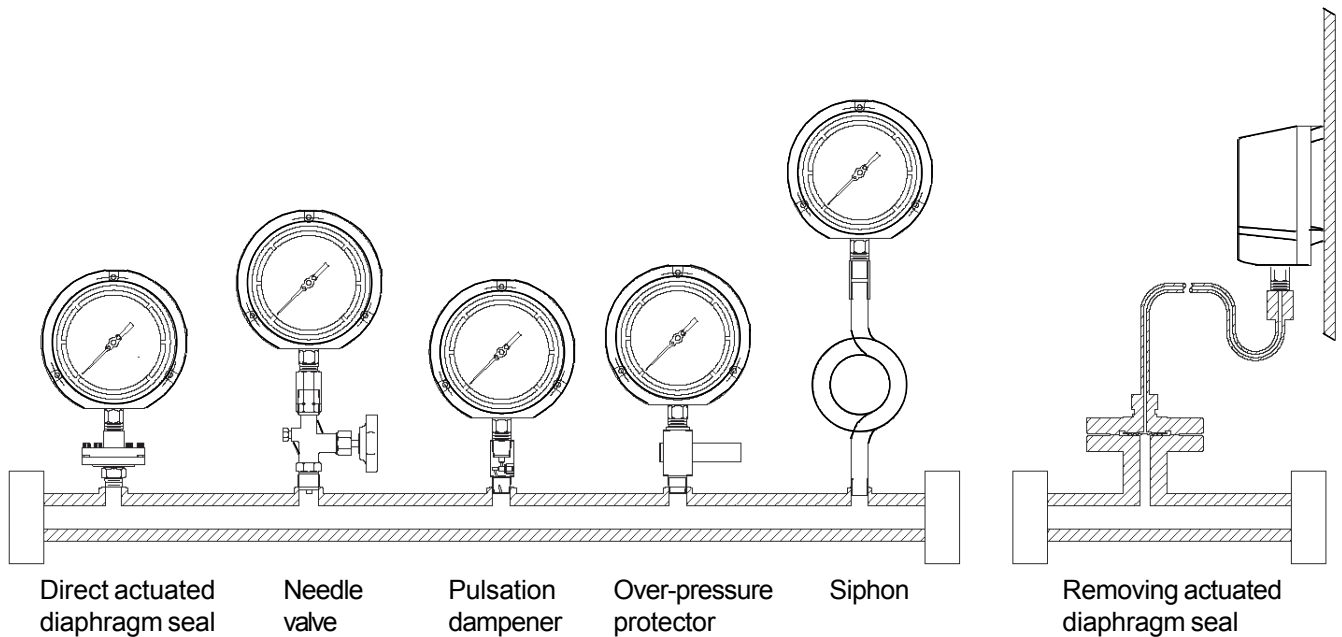

Dimensions:

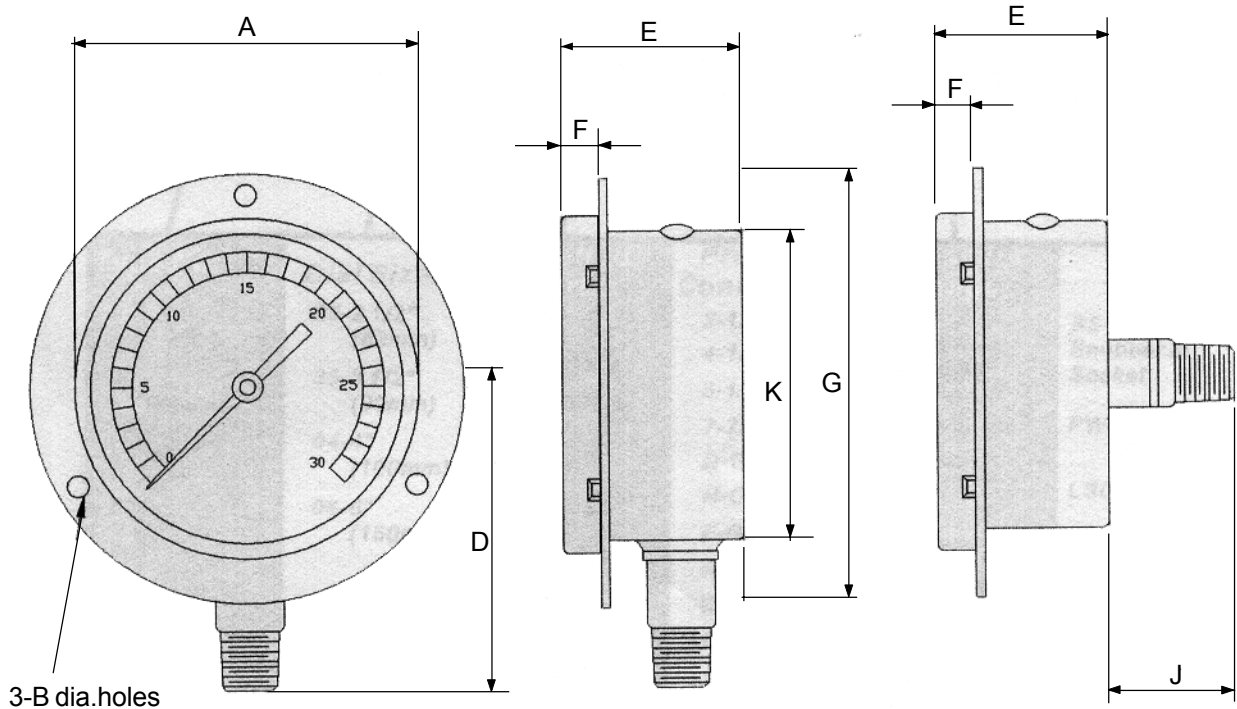

23L(Bottom Connection)

**23B(Center Back Connection)
Lower Back Connection on request**

2 1/2" (63 mm) Dial Size

Type No:	A	B	C	D	E	F	G	H	J	K	L	Weight
23L (2.5")	2.67" (68)	2.67" (4)	2.67" (80)	2.21" (56)	1.26" (32)	0.39" (10)	3.46" (88)	X	X	2.44" (62)	X	0.18-0.25 Kg
23B (2.5")	2.67" (68)	2.67" (4)	2.67" (80)	X	1.26" (32)	0.39" (10)	3.46" (88)	X	0.91" (23)	2.44" (62)	X	0.18-0.25 Kg

3 1/2" (90 mm) Dial Size

Type No:	A	B	C	D	E	F	G	H	J	K	L	Weight
23L (3.5")	4.01" (102)	0.24" (6)	4.72" (120)	3.07" (78)	1.34" (34)	0.47" (12)	5.16" (131)	X	X	3.58" (91)	X	0.37-0.45 Kg
23B (3.5")	4.01" (102)	0.24" (6)	4.72" (120)	X	1.34" (34)	0.47" (12)	5.16" (131)	X	0.91" (23)	3.58" (91)	X	0.37-0.45 Kg

Order Information:

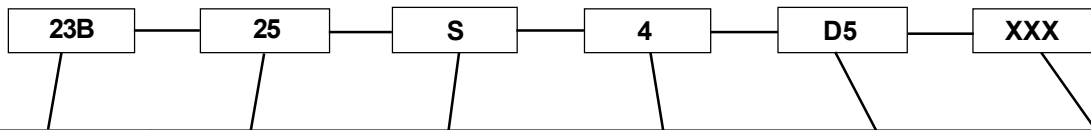

<p>Type No: 23L-Lower (Bottom) Connection 23B-Lower or Center Back Connection</p>	<p>Dial Sizes: 25-2 1/2" (63 mm) 35-3 1/2" (90 mm) 04-4" (100 mm) 06-6" (150 mm)</p>	<p>Wetted Part: S-316SS M-Monel B-Brass</p>	<p>Process Connection: 2-1/2" NPT 4-1/4" NPT 8-1/8" NPT 7-7/16" UNF D-G1/2 H-G3/8 E-G1/4 A-R1/2 G-R3/8 B-R1/4 L-Others 9-9/16" UNF</p>	<p>Pressure Range: Please refer to the range table and write down the code you need. Vacuum Compound Pressure</p>	<p>Option: SS-Threaded Snubber in Socket PW-Polycarbonate Window LSG-Laminated Safety Glass Lens TSG-Tempered Safety Glass Lens UC-U-clamp Kit</p>
---	--	--	---	---	---



23B(Center Back Connection)
Lower Back Connection on request



22L(Bottom Connection)